



# INTELLIS

## ModBus® Network Monitor Model 7504, 7544 and 7579

Installation and Operation Manual



# Revision History

## **Revision 1.0**

12 December 2000

Initial Version

## **Revision 1.1**

28 February 2001

Changed Format and Increased System Information Coverage

## **Revision 1.2**

19 February 2004

Updated document to reflect MPAC design.

# 1 Introduction

	<b>Page No.</b>
<b>Scope of Manual</b>	<b>1-1</b>
<b>Symbols Used in this Document</b>	<b>1-2</b>
<b>About Modbus</b>	<b>1-3</b>
<b>Westlock Intellis Modbus Module EL-40127</b>	<b>1-3</b>
Module Bit Map	<b>1-4</b>
LED Status Indicators	<b>1-4</b>
EL-40127 Module Layout	<b>1-6</b>
<b>Modbus Specifications</b>	<b>1-6</b>
Specifications	<b>1-6</b>
EL-40127 Current Consumption	<b>1-7</b>

## 1.1 *Scope of Manual*

This manual contains installation, configuration and specification data for the DPAC DeviceNet valve controller.

This manual assumes a basic level of familiarity and competence with DeviceNet terminology and technology. Only qualified personnel should install, operate and maintain this equipment.

## 1.2 *Symbols Used in this Document*



This symbol warns the user of possible danger. Failure to heed this warning may lead to personal injury or death and/or severe damage to equipment.



**Attention**

This symbol identifies information about operating the equipment in a particular manner that may damage it or result in a system failure. Failure to heed this warning can lead to total failure of the equipment or any other connected equipment.



**Note**

This symbol draws attention to information that is essential for understanding the operation and/or features of the equipment.

## 1.3 About Modbus

The ModBus, protocol has been placed in the public domain, operates over a serial interface and is supported by almost every PLC,DCS and operator interface (OI) companies.

The ModBus, Intellis 7500 Series network system utilizes the ModBus, RTU protocol. A single ModBus, Intellis system will support up to 10 independent automated valve networks, controlling and monitoring a maximum of 100 valves per network. each network will support 800 programmable discrete I/O points or 8000 I/O points per system.

The ModBus Intellis 7500 Series network system consists of:

1. 7500 Series network monitors that read and transmit valve status and turn the valves on and off.
2. A Network Interface Manager (NIM) that controls the network monitors and communicates with the host **PLC, PC or DCS**.
3. An optional maintenance PC to host the diagnostic Telanetics software.

For high uptime applications, options exist for redundancy of network communications and control

## 1.4 Westlock Intellis ModBus Module EL-40127

The EL-40127 module is a six input, toggled dual dependent output network monitor. Inputs are active high/low (activated by pulling the input up to V+ or down to signal ground). The output is open drain active low FET with diode protection. When the output bit of a slave is forced high, coil A is energized and coil B is de-energized. When the output bit is forced low, coil A is de-energized and coil B is energized. Coil A energized activates the top "open" limit switch and sends bit 4 of the status word high. Coil B energized activates the bottom "closed" limit switch and sends bit 3 of the status word high.

The module consumes 50mA of current with all inputs and outputs active (20mA explosion-proof coil). Minimum power supply input voltage is 19 VDC to insure solenoid operation. A maximum of 30 VDC may be applied to the Network, higher voltages will damage electrical components.

Connection to the Network is via a twisted shielded pair, 22-18 AWG, for data and two conductors for power, 22-12 AWG. The Network topology is a closed loop. The EL-40127 module slaves communicate with the NIM master via RS485.

For data exchange to occur, each network monitor connected to the network must be programmed with a unique address numbered between 0-99, via the handheld programmer or module DIP switches. The address, which can be changed at any time, is stored internally in a EEPROM.

Two terminating resistors, each 120 Ohm 1/2 watt, are required at each end of network loop. These are incorporated in the circuitry of the Dual Loop Master Card.

### 1.4.1 Module Bit Map

<b>Table 1</b>			
<b>I/O</b>	<b>TYPE</b>	<b>MODULE REFERENCE</b>	<b>BITMAP OF DATA</b>
Input 0	Active High/Low <sup>1</sup>	Closed (Bottom) Limit Switch	Function_2, Status Word, Bit 3
Input 1	Active High/Low <sup>1</sup>	Open (Upper) Limit Switch	Function_2, Status Word, Bit 4
Aux. Input 1	Active High/Low <sup>1</sup>	J3, Pin_2 (J3, Pin_1 or 6 Ground)	Function_2, Status Word, Bit 0
Aux. Input 2	Active High/Low <sup>1</sup>	J3, Pin_3 (J3, Pin_1 or 6 Ground)	Function_2, Status Word, Bit 8
Aux. Input 3	Active High/Low <sup>1</sup>	J3, Pin_4 (J3, Pin_1 or 6 Ground)	Function_2, Status Word, Bit 9
Aux. Input 4	Active High/Low <sup>1</sup>	J3, Pin_5 (J3, Pin_1 or 6 Ground)	NOTE: Input not available for use with NIM
Output 1	Active Low <sup>2</sup>	J2, Pin_1: V+, Pin_2: Open Collector	Function_1, 5 & 15 Output Coils, Bit 0 Hi
Output 2	Active Low <sup>2</sup>	J2, Pin_3: V+, Pin_4: Open Collector	Function_1, 5 & 15 Output Coils, Bit 0 Lo

<sup>1</sup> Active High indicates that pulling the input pin up to V+ activates the input. Active Low indicates that pulling the input pin down to ground activates the input.

<sup>2</sup> Active Low indicates that when the output is activated it pulls the output pin down to Ground, drawing current through the load, from the +24V.

### 1.4.2 LED Status Indicators

The LEDs provide information concerning the status of inputs, outputs, the module and/or the network. The LEDs provide visual indication whether any inputs or outputs are active and whether the module or network is in a fault condition. The I/O Status LEDs are intended to indicate the state of the inputs and outputs of the module, not necessarily the on/off condition of the I/O points themselves.

**Table 2**

Module p/n	LED	State	Indicates
EL-40127	Output 2 LED 1	Off	Device powered up but no output data written to device.
		Green	Output de-energized.
		Red	Output energized.
	Output 1 LED 2	Off	Device powered up but no output data written to device.
		Green	Output de-energized.
		Red	Output energized.
	Aux. Input 4 LED 3	Yellow	Aux. Input active
	Aux. Input 3 LED 4	Yellow	Aux. Input active NOTE: Input not available for use with NIM.
	Aux. Input 2 LED 5	Yellow	Aux. Input active
	Aux. Input 1 LED 6	Yellow	Aux. Input active
	Closed LS LED 7	Yellow	Valve CLOSED (bottom Limit Sensor)
	Open LS LED 8	Yellow	Valve OPEN (top Limit Sensor)
	RX LED 9	Yellow	Messages being received by MPAC from bus.
	TX LED 10	Yellow	Messages being transmitted by MPAC to bus.

### 1.4.3 EL-40127 Module Layout

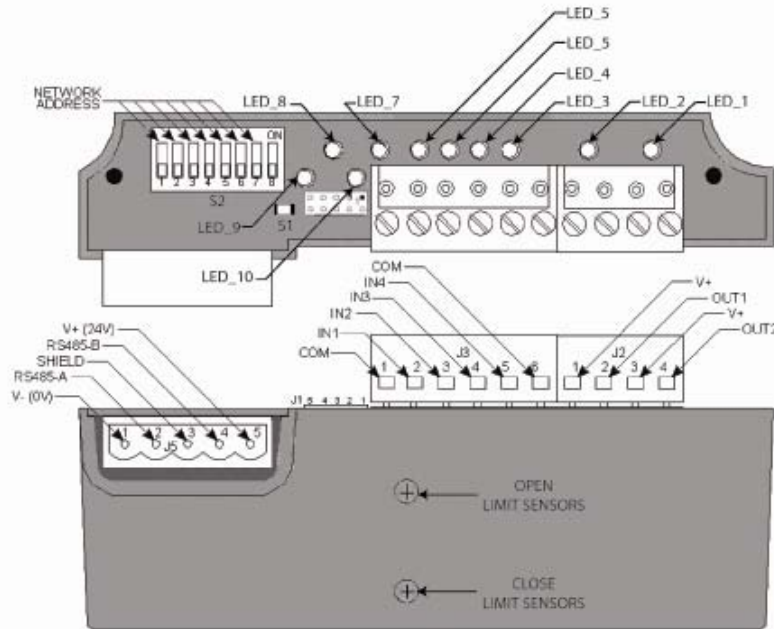

Figure 1

## 1.5 ModBus Specifications

### 1.5.1 Specifications

<b>Physical Media</b>	Twisted pair for communications, 2 wires for power
<b>Maximum Loop Distance</b>	3000 ft. nominal, 4000 ft. max.
<b>Max. Network Monitors/ System</b>	100 slaves/ Network with 10 Networks/ System
<b>Maximum I/O Points</b>	800/ Network, 8000/ System
<b>Current Consumption of Slave</b>	50 mA including 20 mA for solenoid
<b>Interface Capability</b>	Any PLC or DCS with a Modbus port
<b>Communications Method</b>	Master/Slave with cyclic polling
<b>Error Checking</b>	CRC
<b>Network Topologies Supported</b>	Closed Loop
<b>Baud Rate</b>	9.6 kbd
<b>System Redundancy</b>	Field communication from both ends of loop and hot swap NIMs as an option
<b>Valve Specific Diagnostics</b>	Yes, see Appendix B for details

## 1.5.2 EL-40127 Current Consumption

<b>Table 4</b>		
<b>NI Falcon Solenoid</b>		
<b>Input Active</b>	<b>Output Active</b>	<b>Current Draw@ 24 Vdc</b>
0	0	27 mA
1 Limit Sensors	0	28 mA
2 Limit Sensors	1	48 mA
1 Aux. Input	0	30 mA
3 Aux. Input	1	56 mA

## 2 Installation Instructions

Page No.

<b>Mounting</b>	<b>2-2</b>
<b>Pneumatic Connections</b>	<b>2-3</b>
Tubing and Fittings	2-3
Porting	2-4
Maintenance	2-4
<b>Switch Adjustment</b>	<b>2-4</b>
<b>Wiring Instructions</b>	<b>2-5</b>
MPAC Connector Pin Out	2-7
<b>Device Configuration</b>	<b>2-8</b>
Setting the Modbus Slave Address via the Handheld Programmer	2-8
Setting the Modbus Slave Address via the DIP Switch	2-9
<b>Modbus Supported Topologies</b>	<b>2-12</b>



**IMPORTANT:** If the valve monitor is already in the field mounted on an actuator and valve, please follow the field wiring instructions in Section 2.4.

**Note**



Confirm that the area is known to be non-hazardous before opening the cover of a network monitor and making or breaking any electrical connections.

**Warning**

## 2.1 Mounting

For steps 1-3 refer to Figure 2 below.

1. Attach the proper mounting bracket and adapter (if required) to the valve monitor housing with the hardware provided.
2. Operate the actuator to full closed position.
3. Attach the valve monitor and mounting bracket to the actuator.

Note the position of the actuator/valve and confirm the Beacon position is properly aligned, as shown in Figure 3 below while replacing the cover.

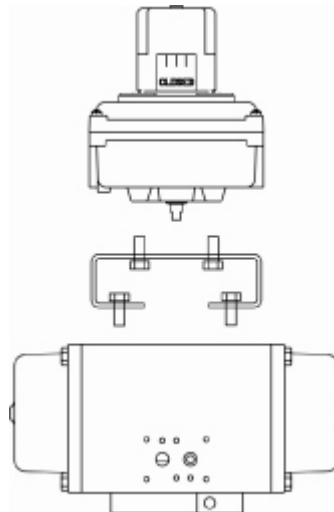

**Figure 2**

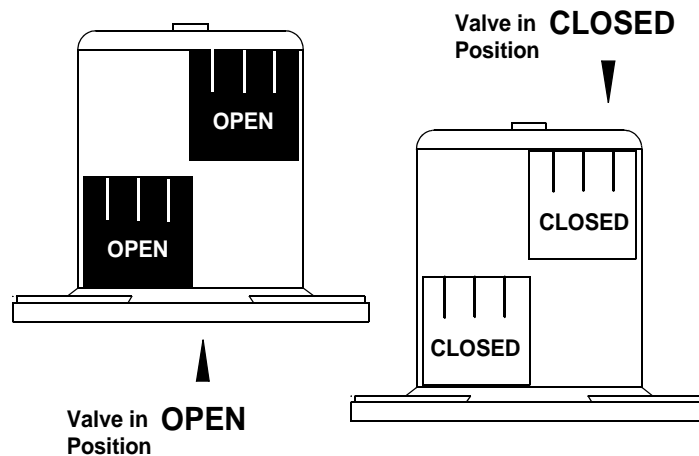

Figure 3

## 2.2 Pneumatic Connections

Personal injury and/or property damage may occur from loss of process control if the supply medium is not clean, dry oil-free air or non-corrosive gas. Instrument quality air that meets the requirements of ISA Standard S7.3-1975 is recommended for use with pneumatic equipment in process control environments. Westlock Controls recommends the use of a 20 micron filter with all Falcon solenoids.



### 2.2.1 Tubing and Fittings

The use of copper, stainless steel, nylon or polyethylene tube is recommended for piping up air circuits and equipment. As a general rule, pipe threaded fittings should not be assembled to a specific torque because the torque required for a reliable joint varies with thread quality, port and fitting materials, sealant used, and other factors. The suggested method of assembling pipe threaded connections is to assemble them finger tight and then wrench tighten further to a specified number of turns from finger tight. The assembly procedure given below is for reference only; the fitting should not be over tightened for this will lead to distortion and most likely, complete valve failure.

1. Inspect port and connectors to ensure that the threads on both are free of dirt, burrs and excessive nicks.
2. Apply sealant/lubricant or Teflon tape to the male pipe threads. With any sealant tape, the first one or two threads should be left uncovered to avoid system contamination.
3. Screw the connector into the port to the finger tight position.
4. Wrench tighten the connector approximately 1 - 2 turns (to seal) from finger tight.

Again this is only reference - the fitting should NOT be over tightened.



**Note**

Delrin valve bodies are fitted with helicoils therefore an extra effort should be made **NOT** to over tighten pipe fittings or retaining screws (.5 - 1 turns from finger tight to seal). Over tightening will result in valve failure or pull helicoils from valve body.

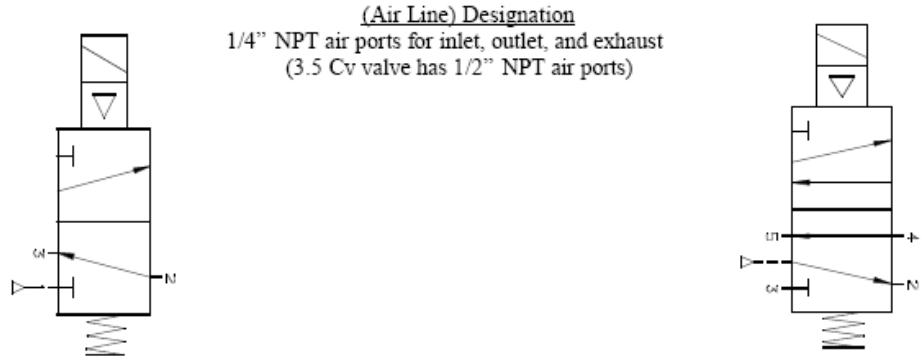

(Air Line) Designation  
1/4" NPT air ports for inlet, outlet, and exhaust  
(3.5 Cv valve has 1/2" NPT air ports)

**Description of Operation:** Solenoid De-energized - air flows from Outlet Port 2 to Exhaust Port 3.  
Solenoid Energized - air flows from Inlet Port 1 to Outlet Port 2.

**Description of Operation:** Solenoid De-energized - air flows from Inlet Port 1 to Outlet Port 2 and exhausts from Port 4 to Port 5. Solenoid Energized - air flows from Inlet Port 1 to Outlet Port 4 and exhausts from Port 2 to Port 3.

### 2.2.3 Maintenance

Routine maintenance is usually confined to the periodic replenishment of Dow Corning III lubricant or equivalent to spool and spring.

### 2.3 Switch Adjustment



**Note**

Switches are factory set. If you need to adjust switches for any reason follow instructions below.

For steps 1-8 refer to Figures 1 and 4.

1. Refer to Figure 1 and note the approximate locations of the Open and Close targets on the MPAC module.
2. With the valve in the closed position, lift bottom cam of the Close sensor trigger.
3. Turn cam until face of trigger is perpendicular to the target and sensor is activated as evidenced by the lighting of the corresponding module LED.
4. Release the cam and the spring will push cam back onto the splined shaft.

5. Operate the actuator to the opened position.
6. Push down the top cam of the Open sensor trigger.
7. Turn cam until face of trigger is perpendicular to the target and sensor is activated as evidenced by the lighting of the corresponding module LED.
8. Operate actuator from one extreme to the other several times to check Limit Sensor operation.

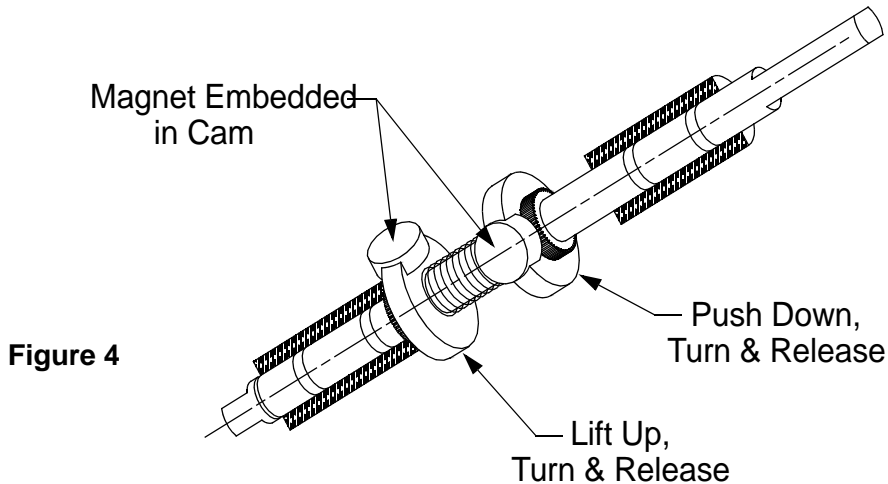

## 2.4 Wiring Instructions



**All wiring must be in accordance with National Electrical Code (ANSI-NFPA-70) for the appropriate area classifications.**

All wiring must be in accordance with National Electrical Code (ANSI-NFPA-70) for area classifications. The valve monitors are approved as nonincendive for Class I, Division 2, Groups A,B,C and D; dust-ignition proof for Class II/III, Division 1, Groups E,F and G hazardous (classified) locations; indoor/outdoor (NEMA type 4, 4X).



Always check the nameplate to make sure the agency approval ratings coincide with the application.



The proper wiring diagram for your unit is shown on the inside of the enclosure cover.

**Note**

1. Wiring options for 7544 and 7579 are shown in Figures 5 and 6 below.
2. Replace the electronics housing cover or junction housing cover.
3. Unit is now ready for automatic operation. If any assistance is required, please call Westlock Controls at (201) 794-7650.

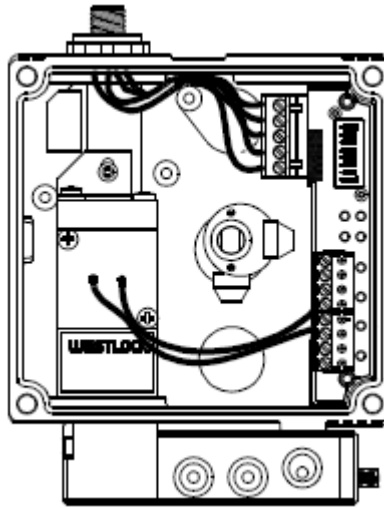

**Figure 5**

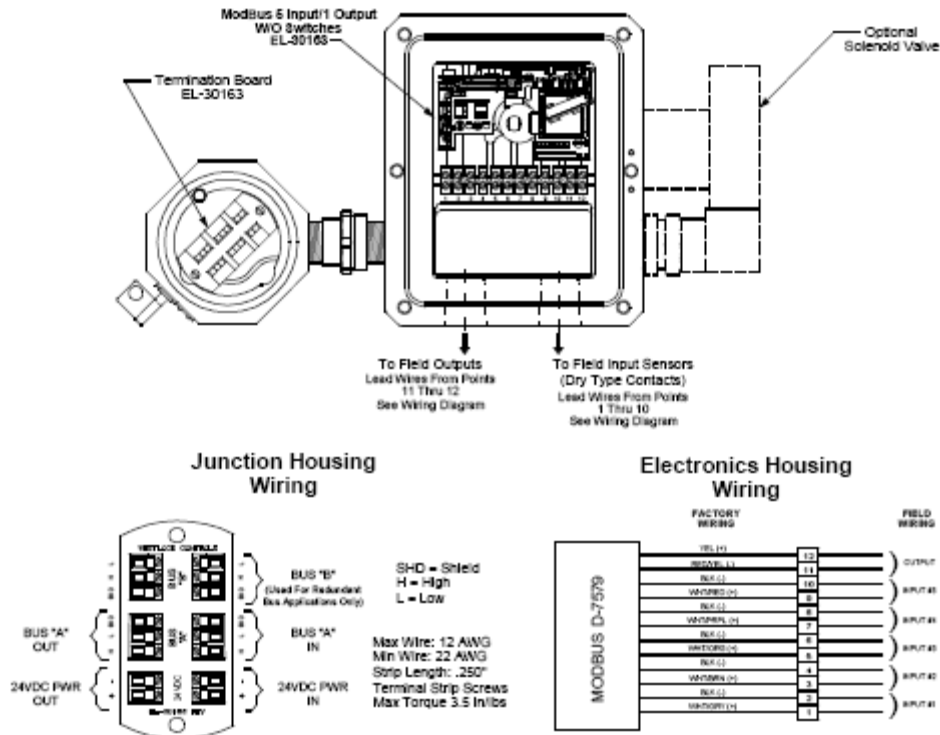
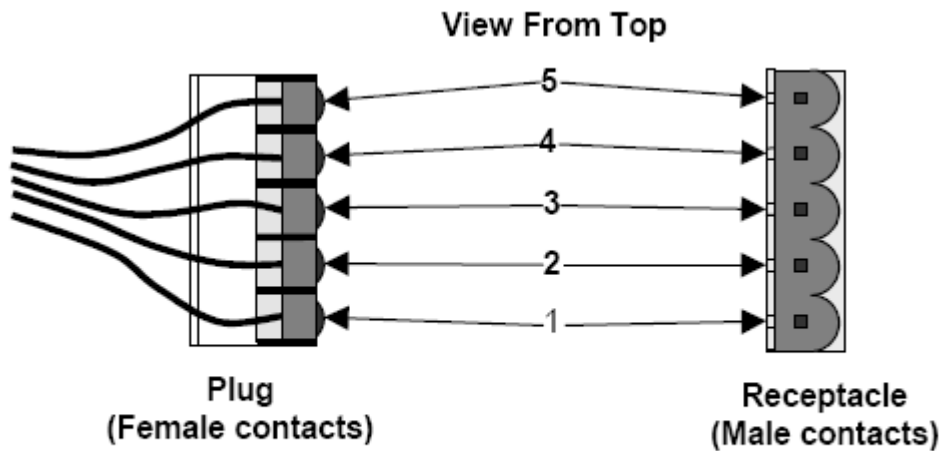

Figure 6

### 2.4.1 Modbus Connector Pin Out



5 – Pin Open Connector

Figure 7

<b>Table 5</b>	
<b>PIN #</b>	<b>FUNCTION</b>
1	V- (0Vdc)
2	RS485-A
3	SHIELD
4	RS485-B
5	V+ (24Vdc)

## 2.5 Device Configuration



Allowable MPAC slave address range is 0-99. It is recommended that the address begin at zero and increase sequentially so as to minimize the number of polling slots required of the NIM thereby improving polling performance.

**Note**



If any of the DIP switch positions are in the down or OFF position the slave address will be determined by the DIP switch setting.

**Note**

### 2.5.1 Setting the Modbus Slave Address via the Handheld Programmer



Refer to the Modbus HHP IOM, **tech-134**, for detailed information on the use of the Modbus HHP.

**Note**

For steps 1- 6 refer to Figures 8 and 9.

1. Set all S2 switch positions (1-8) to the **ON** position.
2. Attach the HHP.
3. Cycle power to the MPAC.
4. Set slave address with HHP.
5. Cycle power to the MPAC.
6. Validate new slave address via HHP.

## 2.5.2 Setting the Modbus Slave Address via the DIP Switches



If the DIP switch positions 1-8 are all in the ON or up position the slave address will be the one that was last set using the HHP and stored in the slaves EEPROM.

### Note

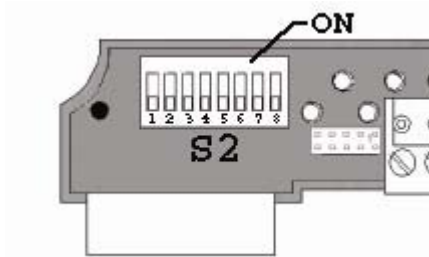

Figure 8

The Modbus slave address is configured by setting the binary address on selector switch S2 (See Figure 8 above). Examples are shown below in Figure 9.

See Table 6 for a listing of switch positions by decimal address.

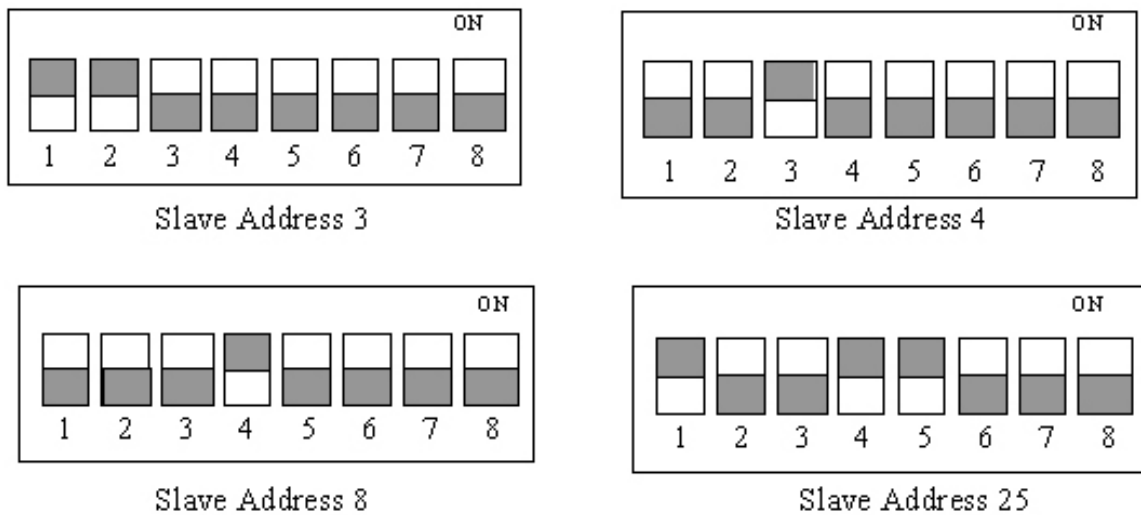

Figure 9

<b>Table 6</b>							
<b>S2 Switch Positions</b>							
<b>SW_1</b> <b>2<sup>0</sup></b>	<b>SW_2</b> <b>2<sup>1</sup></b>	<b>SW_3</b> <b>2<sup>2</sup></b>	<b>SW_4</b> <b>2<sup>3</sup></b>	<b>SW_5</b> <b>2<sup>4</sup></b>	<b>SW_6</b> <b>2<sup>5</sup></b>	<b>SW_7</b> <b>2<sup>6</sup></b>	<b>Decimal Slave Address</b>
OFF	OFF	OFF	OFF	OFF	OFF	OFF	<b>0</b>
ON	OFF	OFF	OFF	OFF	OFF	OFF	<b>1</b>
OFF	ON	OFF	OFF	OFF	OFF	OFF	<b>2</b>
ON	ON	OFF	OFF	OFF	OFF	OFF	<b>3</b>
OFF	OFF	ON	OFF	OFF	OFF	OFF	<b>4</b>
ON	OFF	ON	OFF	OFF	OFF	OFF	<b>5</b>
OFF	ON	ON	OFF	OFF	OFF	OFF	<b>6</b>
ON	ON	ON	OFF	OFF	OFF	OFF	<b>7</b>
OFF	OFF	OFF	ON	OFF	OFF	OFF	<b>8</b>
ON	OFF	OFF	ON	OFF	OFF	OFF	<b>9</b>
OFF	ON	OFF	ON	OFF	OFF	OFF	<b>10</b>
ON	ON	OFF	ON	OFF	OFF	OFF	<b>11</b>
OFF	OFF	ON	ON	OFF	OFF	OFF	<b>12</b>
ON	OFF	ON	ON	OFF	OFF	OFF	<b>13</b>
OFF	ON	ON	ON	OFF	OFF	OFF	<b>14</b>
ON	ON	ON	ON	OFF	OFF	OFF	<b>15</b>
OFF	OFF	OFF	OFF	ON	OFF	OFF	<b>16</b>
ON	OFF	OFF	OFF	ON	OFF	OFF	<b>17</b>
OFF	ON	OFF	OFF	ON	OFF	OFF	<b>18</b>
ON	ON	OFF	OFF	ON	OFF	OFF	<b>19</b>
OFF	OFF	ON	OFF	ON	OFF	OFF	<b>20</b>
ON	OFF	ON	OFF	ON	OFF	OFF	<b>21</b>
OFF	ON	ON	OFF	ON	OFF	OFF	<b>22</b>
ON	ON	ON	OFF	ON	OFF	OFF	<b>23</b>
OFF	OFF	OFF	ON	ON	OFF	OFF	<b>24</b>
ON	OFF	OFF	ON	ON	OFF	OFF	<b>25</b>
OFF	ON	OFF	ON	ON	OFF	OFF	<b>26</b>
ON	ON	OFF	ON	ON	OFF	OFF	<b>27</b>
OFF	OFF	ON	ON	ON	OFF	OFF	<b>28</b>
ON	OFF	ON	ON	ON	OFF	OFF	<b>29</b>
OFF	ON	ON	ON	ON	OFF	OFF	<b>30</b>
ON	ON	ON	ON	ON	OFF	OFF	<b>31</b>
OFF	OFF	OFF	OFF	OFF	ON	OFF	<b>32</b>
ON	OFF	OFF	OFF	OFF	ON	OFF	<b>33</b>
OFF	ON	OFF	OFF	OFF	ON	OFF	<b>34</b>
ON	ON	OFF	OFF	OFF	ON	OFF	<b>35</b>
OFF	OFF	ON	OFF	OFF	ON	OFF	<b>36</b>
ON	OFF	ON	OFF	OFF	ON	OFF	<b>37</b>

OFF	ON	ON	OFF	OFF	ON	OFF	38
ON	ON	ON	OFF	OFF	ON	OFF	39
OFF	OFF	OFF	ON	OFF	ON	OFF	40
ON	OFF	OFF	ON	OFF	ON	OFF	41
OFF	ON	OFF	ON	OFF	ON	OFF	42
ON	ON	OFF	ON	OFF	ON	OFF	43
OFF	OFF	ON	ON	OFF	ON	OFF	44
ON	OFF	ON	ON	OFF	ON	OFF	45
OFF	ON	ON	ON	OFF	ON	OFF	46
ON	ON	ON	ON	OFF	ON	OFF	47
OFF	OFF	OFF	OFF	ON	ON	OFF	48
ON	OFF	OFF	OFF	ON	ON	OFF	49
OFF	ON	OFF	OFF	ON	ON	OFF	50
ON	ON	OFF	OFF	ON	ON	OFF	51
OFF	OFF	ON	OFF	ON	ON	OFF	52
ON	OFF	ON	OFF	ON	ON	OFF	53
OFF	ON	ON	OFF	ON	ON	OFF	54
ON	ON	ON	OFF	ON	ON	OFF	55
OFF	OFF	OFF	ON	ON	ON	OFF	56
ON	OFF	OFF	ON	ON	ON	OFF	57
OFF	ON	OFF	ON	ON	ON	OFF	58
ON	ON	OFF	ON	ON	ON	OFF	59
OFF	OFF	ON	ON	ON	ON	OFF	60
ON	OFF	ON	ON	ON	ON	OFF	61
OFF	ON	ON	ON	ON	ON	OFF	62
ON	ON	ON	ON	ON	ON	OFF	63
OFF	OFF	OFF	OFF	OFF	OFF	ON	64
ON	OFF	OFF	OFF	OFF	OFF	ON	65
OFF	ON	OFF	OFF	OFF	OFF	ON	66
ON	ON	OFF	OFF	OFF	OFF	ON	67
OFF	OFF	ON	OFF	OFF	OFF	ON	68
ON	OFF	ON	OFF	OFF	OFF	ON	69
OFF	ON	ON	OFF	OFF	OFF	ON	70
ON	ON	ON	OFF	OFF	OFF	ON	71
OFF	OFF	OFF	ON	OFF	OFF	ON	72
ON	OFF	OFF	ON	OFF	OFF	ON	73
OFF	ON	OFF	ON	OFF	OFF	ON	74
ON	ON	OFF	ON	OFF	OFF	ON	75
OFF	OFF	ON	ON	OFF	OFF	ON	76
ON	OFF	ON	ON	OFF	OFF	ON	77
OFF	ON	ON	ON	OFF	OFF	ON	78
ON	ON	ON	ON	OFF	OFF	ON	79

OFF	OFF	OFF	OFF	ON	OFF	ON	80
ON	OFF	OFF	OFF	ON	OFF	ON	81
OFF	ON	OFF	OFF	ON	OFF	ON	82
ON	ON	OFF	OFF	ON	OFF	ON	83
OFF	OFF	ON	OFF	ON	OFF	ON	84
ON	OFF	ON	OFF	ON	OFF	ON	85
OFF	ON	ON	OFF	ON	OFF	ON	86
ON	ON	ON	OFF	ON	OFF	ON	87
OFF	OFF	OFF	ON	ON	OFF	ON	88
ON	OFF	OFF	ON	ON	OFF	ON	89
OFF	ON	OFF	ON	ON	OFF	ON	90
ON	ON	OFF	ON	ON	OFF	ON	91
OFF	OFF	ON	ON	ON	OFF	ON	92
ON	OFF	ON	ON	ON	OFF	ON	93
OFF	ON	ON	ON	ON	OFF	ON	94
ON	ON	ON	ON	ON	OFF	ON	95
OFF	OFF	OFF	OFF	OFF	ON	ON	96
ON	OFF	OFF	OFF	OFF	ON	ON	97
OFF	ON	OFF	OFF	OFF	ON	ON	98
ON	ON	OFF	OFF	OFF	ON	ON	99

## 2.6 Modbus Supported Topologies



### Attention

The Westlock Modbus system only supports a zero drop closed loop topology.

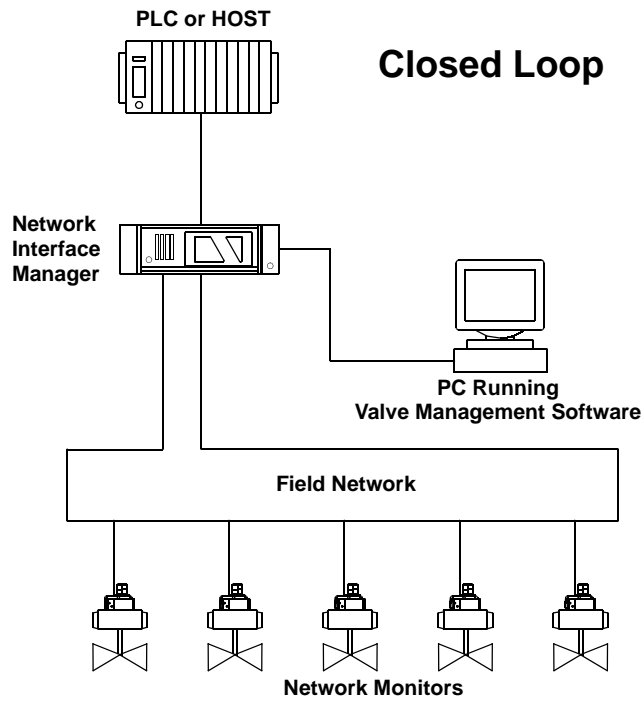

**Figure 10**

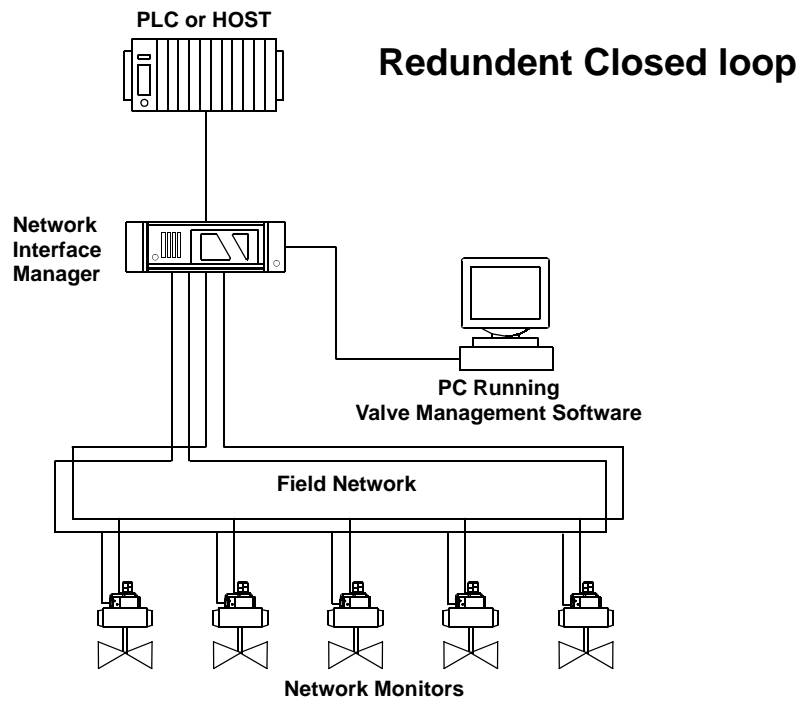

**Figure 11**

# 3 Westlock Modbus System

Page No.

<b>Westlock Modbus System Architecture Overview</b>	<b>3-2</b>
<b>Westlock Modbus Slave Communication</b>	<b>3-3</b>
<b>Maximum Trunk and Drop Lengths</b>	<b>3-4</b>

### 3.1 Westlock Modbus System Architecture Overview

The Westlock NETWORK INTERFACE MANAGER (NIM) supervises the exchange of signal data between Network Monitors on the Westlock field network and a host DCS, PC or PLC; it is also configured to monitor and report on additional process signals from the Network Monitors required for diagnostics or safety.

The host system must be capable of issuing commands using the Modbus RTU protocol to read or write the control data through the NIM's built-in Modbus port. Diagnostic data is sent to a PC running Telanetics software, through a built-in serial port via RS232. RS485 line drivers are used to connect Network Monitors to the NIM via a shielded twisted pair in a RS-485 closed loop.

Figure 12

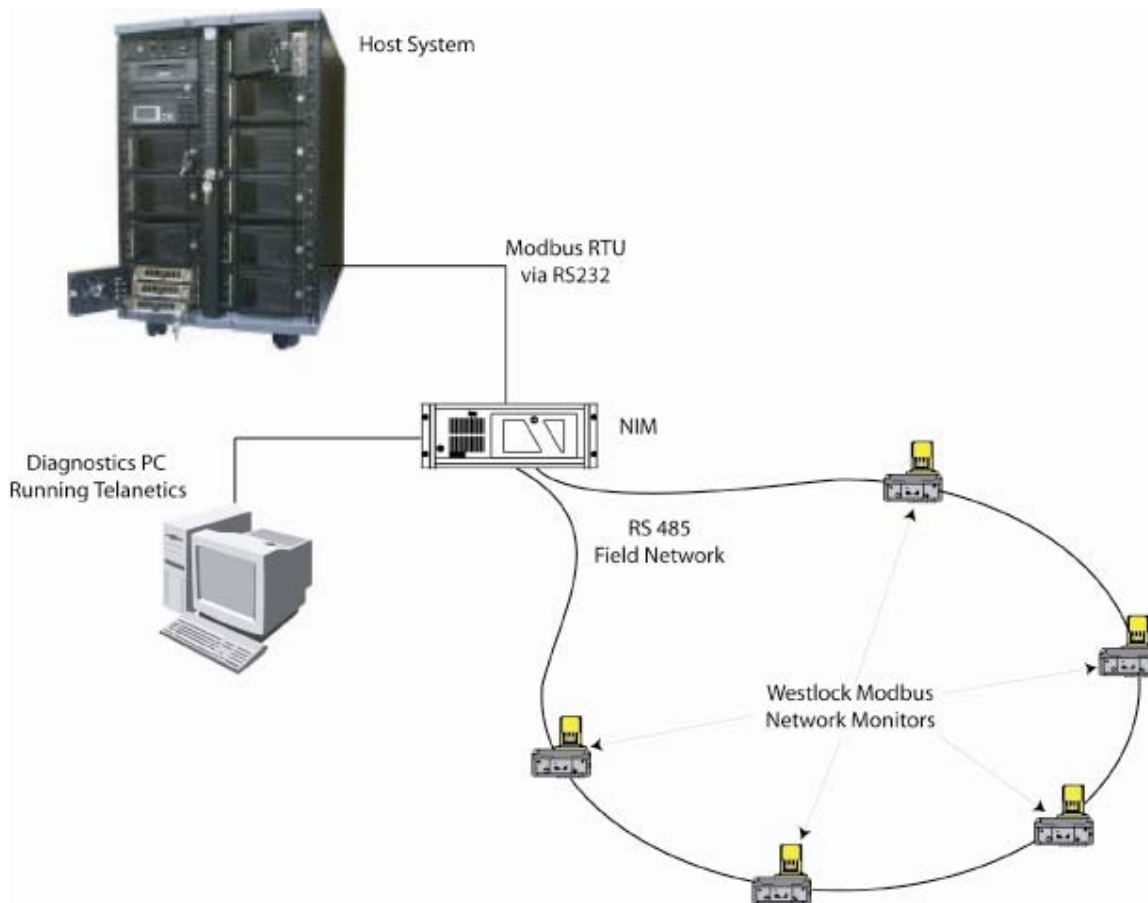

## 3.2 Westlock Modbus Slave Communication

The host controller (designated as Master) communicates to the NIM (designated as Slave) by a Master-Slave technique, in which only one device (the Master) can initiate transactions referred to as “queries”. These transactions typically consist of commands for reading or modifying registers, coils or discrete inputs. The NIM (Slave) responds by supplying the requested data to the Master or by taking the action requested in the query. Interfacing the NIM to a PLC or DCS is implemented via a RS232 Modbus port in the NIM. Data transfer is at 9600 Baud.



For a more detailed treatment of this topic refer to the *ModBus® Protocol Implementation Guide*, document NIM100.

### Note

Data transfer between the host and the automated valve network is through shared data tables. The host reads input values from an input data table in the NIM and writes all output values to an output data table in the NIM. The NIM polls the Network Monitors in the field and updates the input data table with the information returned while writing the output data table updated by the host to the Network Monitors. Communications between the NIM and the Network Monitors are via a RS485 closed loop. Data transfer is at 9600 Baud.



For a more detailed treatment of this topic refer to the *NIM Communications Protocols*, document NIM101

### Note

### 3.3 Maximum Trunk and Drop Lengths



**Attention**

Proper installation of media is essential to the reliable operation of the system. Users must insure that cable of the correct specification is used throughout the installation, that all terminations are correct and that the maximum cable lengths are observed.



**Attention**

The Westlock Modbus system only supports a zero drop closed loop topology.

The nominal bus length for each network is 3000 feet. With the use of a Belden 9162 cable or equivalent a maximum bus length of 4000 feet for each network is allowed.

## **Appendix A**

### **Contact Information**

#### **USA**

Westlock Controls Corp.  
280 Midland Ave.  
Saddle Brook, NJ 07663  
Phone: (201) 794-7650 • Fax: (201) 794-0913  
Email: [herbtucker@westlockcontrols.com](mailto:herbtucker@westlockcontrols.com)  
Internet <http://www.westlockcontrols.com>

#### **Europe**

Westlock Controls UK  
Chapman Way, Tunbridge Wells  
Kent, England TN23EF  
Phone: 011-441-892-516277 • Fax: 011-441-892-516279

#### **South America**

Westlock Equipmentos De Controles Ltda.  
Rua, Sao Paulo 291  
Alphaville, Barueri  
Sao Paulo, CEP 06465-130  
Phone: 011-55-11-7291-0930 • Fax: 011-55-11-7291-0931

## Appendix B

### Network Loading and Polling Times



**Note**

Outputs are written via an interrupt to the DMC therefore slave output data is updated independent of its position in the polling sequence. Inputs are read in strict polling sequence and therefore updates are strictly dependent on a slave's position in the polling sequence.



**Note**

A network with 100 slaves will have a worse case latency for slave status updates of approximately 2.3 seconds. A network with 50 slaves will have a worse case latency for slave status updates of approximately 1.15 seconds.

Polling times are directly proportional to the number of slaves on a network and the number of DualMaster cards (DMC) installed in the NIM. If slave status updates are required within a certain time period the number of slaves installed on a network must be limited. The example below defines how the polling time for a slave's status is determined.

- The scan time for a loop is 0.016 seconds per valve
- The scan time for a Dual-Master card to NIM is 0.1 seconds
- The scan time for a NIM to Modbus is 0.040 seconds

The maximum allowable valves on the network with a one-second-time constraint would be approximately 50 valves.

The time from a command being issued by the DCS or PLC until the command is received and executed at the slave is dependent on the following factors:

- The number of Modbus addresses on the Modbus line (each DMC will have two Modbus addresses).
- The total number of slaves that the NIM is addressing (the NIM central processor will communicate with one DMC with input/output data for a single slave attached to its loop, then go on to the next DMC for a single one of its slaves, and so on down the line, then return back to the first DMC for the next slave on that card).
- The total number of slaves on the loop of the DMC (each slave is addressed in sequence from the lowest address up to the greatest address and then begins at the lowest again).

Each one of the two loops on the DMC is polled independent of the other loop, and inde-

pendent of other loops on other DMC. Communication between the NIM central processor and the DMC is semi-independent of the other DMC, in that it does not have to wait for the other DMC to complete all of the slaves on their loops, but it does have to wait for a single message for each one of the DMC installed in the NIM, before it can get it's next message. An example of the maximum time for a command to reach the slave (in a NIM with 3 DMC with 50 slaves on each one of their loops) is shown below. This is assuming that in each case the message just missed its turn in the sequence.

The command would reach the slave and be executed in less than 1.14 sec. (0.04 + 0.3

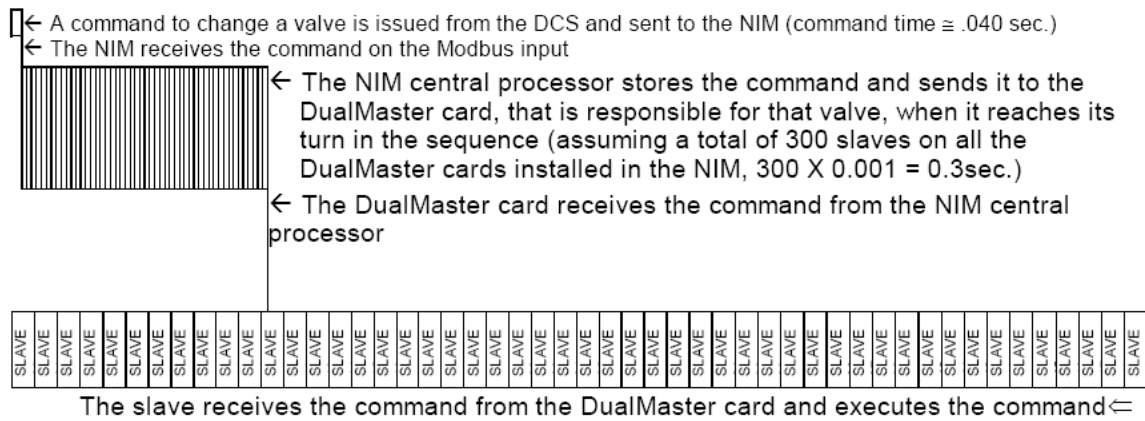

+ 0.8 = 1.14).